



MODULAR
SERVICES COMPANY

PROFILE™

Installation Manual

PROFILE™ HEADWALL



OVERVIEW

The Profile™ is a UL-listed, vertically oriented medical headwall assembly. Profile units are available in single- and double-sided (through the wall) configurations, and may be installed in conjunction with Modular's Bed Docker™ unit. Units are available with either three or four gas outlets per gas pod. Component chases accept standard-depth components such as medical gas outlets, electrical receptacles, nurse call stations, etc. Vertical accessory tracks are an integral part of the Profile headwall, and accept adapters along their entire length. Figure 1 identifies the various components of the Profile unit.

NOTE: Profile™ units are designed to be installed within walls during new construction; however, units may also be surface-mounted. This installation manual details the procedures for inwall installation. For surface-mount applications, follow instructions for Flatwall installation.

UNPACKING AND INSPECTION

1. Upon receipt of Profile™ units and prior to unpacking, inspect shipping containers for damage. Document any damage found and notify the carrier and Modular Services Company.
2. Locate the carton for the unit you wish to install. Labels at each end of the carton identify the unit type and general description of contents, as well as the room number or area of installation (if applicable).
3. Unpack unit from shipping containers, taking care not to damage unit.
4. Inspect units for defects in materials or workmanship prior to installation. It is the responsibility of the customer to report any damage or deficiencies to Modular Services immediately upon discovery.
5. Finish trim and accessory items supplied with the units are located in additional (separate) cartons. These cartons should remain sealed until all finish work (drywall installation, painting, wall coverings, etc.) has been completed.

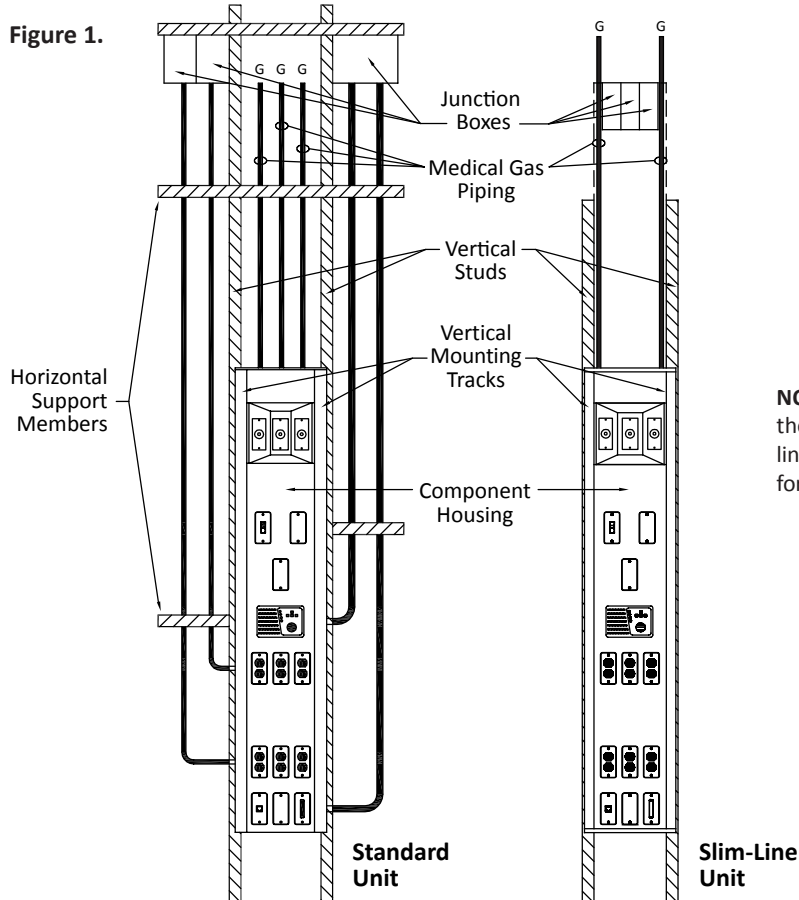

NOTE: Standard-height Profile™ units are depicted in the illustrations. Installation of extended-height or slim-line units with internal raceways is generally the same as for standard-height units, unless otherwise noted.

PREPARATION

1. Review the final approved shop drawings and the submittal booklet, which will provide you with technical details specific to your installation, such as:
 - Wiring diagrams
 - Equipment types and quantities
 - Shop drawings of each type unit
 - Room numbers and locations in building (if applicable)
2. The configuration (either "as shown" or "opposite") for each room will be noted, either on the architectural plans or on approved shop drawings. Please review these documents to ensure that units are being installed correctly.
3. The interior framing of the stud wall where the unit is to be located should allow for the installation of the Profile assembly. The unit will be positioned between two studs that are no less than 31-1/2" apart. If open-ended studs are being used (Figure 2a), the horizontal support members are inserted into the open ends of the stud framing. If the studs have a return leg on the open end, the closed end of the stud should be turned to face the Profile location, and the flanges on the ends of the horizontal support members are attached to the closed side of the studs (Figure 2b).

Particular care should be taken to ensure that the unit is being installed at the proper location, as determined by architectural requirements. **NOTE:** Slim-line Profile units (with a model number ending in -IR) are built on 2-7/8" studs. The unit will fit between studs that are 16" O.C. (overall width is 12.3" for three-gas units and 13.7" for four-gas units), and therefore will not be used for attachment of drywall on the back side of the unit.

WARNING: For installation of the Profile units, make certain walls are constructed of at least 20-gauge steel studs on 16" (41 cm) centerlines, and are covered with a minimum of 5/8" (15.9 mm) drywall. Failure to do so could cause the partition to collapse, resulting in personal injury or property damage.

Figure 2a.

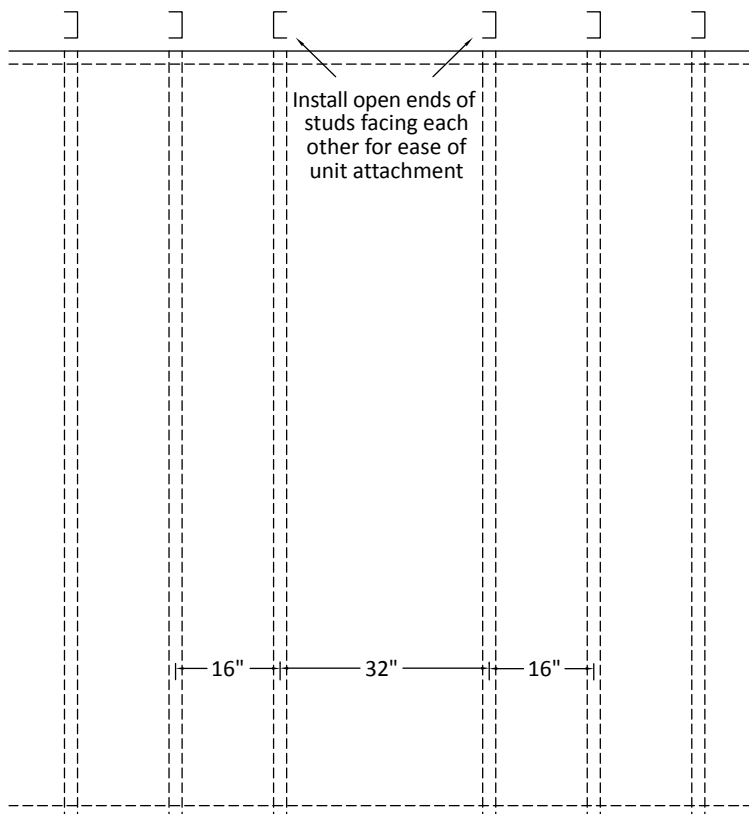
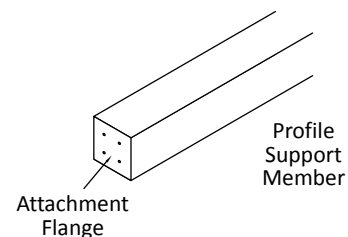
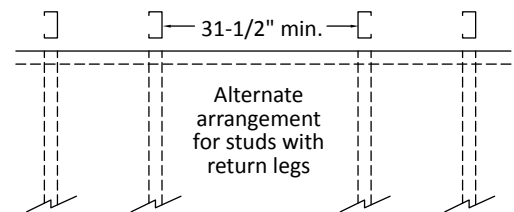

Figure 2b.



UNIT INSTALLATION

1. Set the Profile assembly in place (Figure 3), ensuring that the unit is level before attaching it to the floor track.
2. Install interior framing with standard framing fasteners (not included). Note attachment of horizontal framing members, either on the inside of open-ended studs or outside of studs with a return leg.
3. The header provided at 90" AFF (item 1) may be extended and attached to adjacent wall framing. An additional header may also be installed at the top of unit (item 2), if required.
4. Once the unit is attached in place and level, install additional framing and support prior to drywall installation, as necessary.

MEDICAL GAS CONNECTIONS

Figure 3.

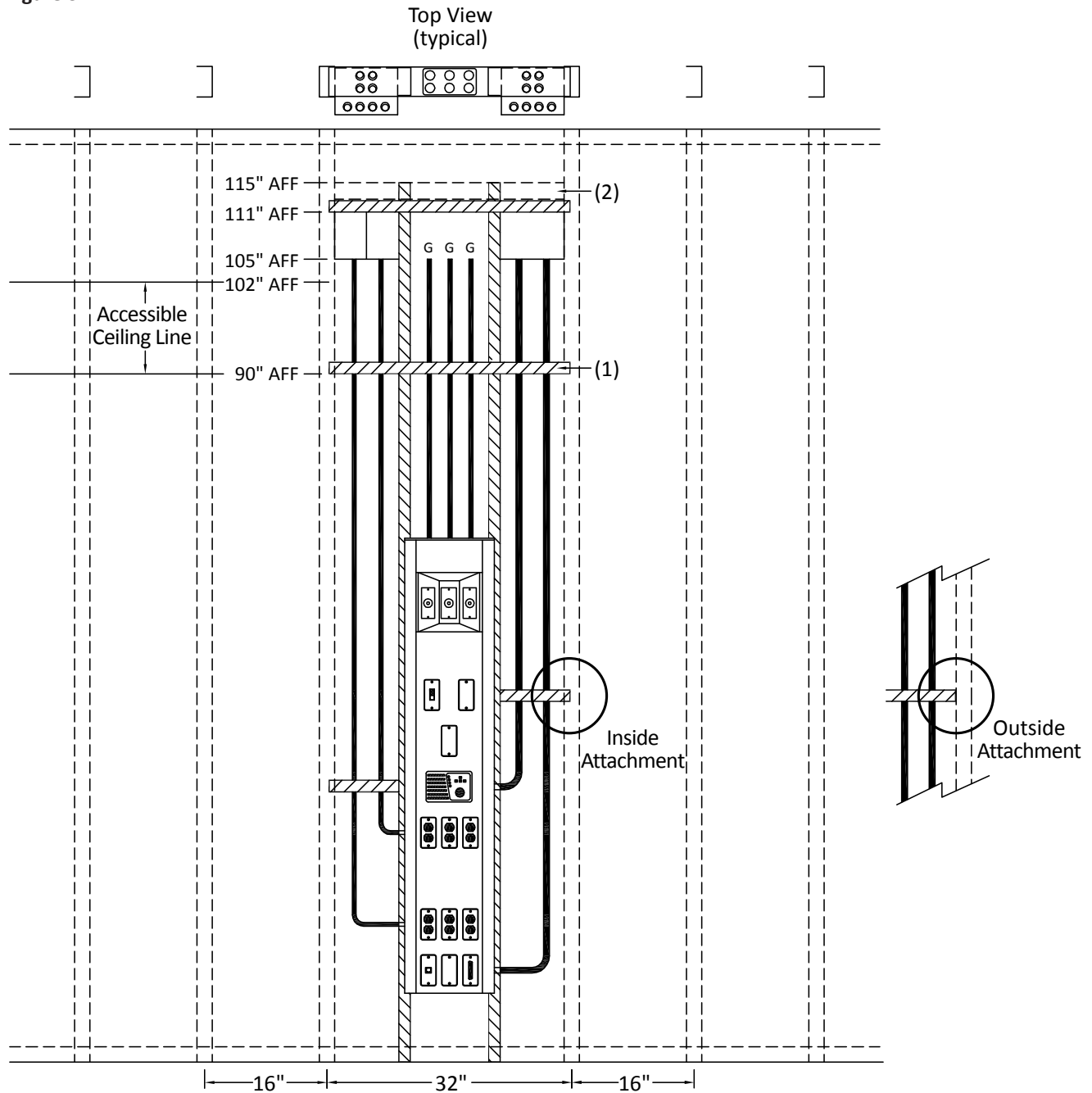

1. Medical gas piping connections are to be made in accordance with NFPA 99 before installation of the drywall.
2. Single-service termination points are provided for each gas service per side. Therefore, on a double-sided unit there will be two service termination points for each medical gas service. The service connections may be joined for the common service by the mechanical contractor, as required (Figure 4).
3. Prior to brazing the pipes together, the component housing should be inspected to ensure that it is set for proper drywall installation. Brazing pipes together with the component housing out of position could create additional stresses on the piping when adjusted for drywall finish.

Figure 4.

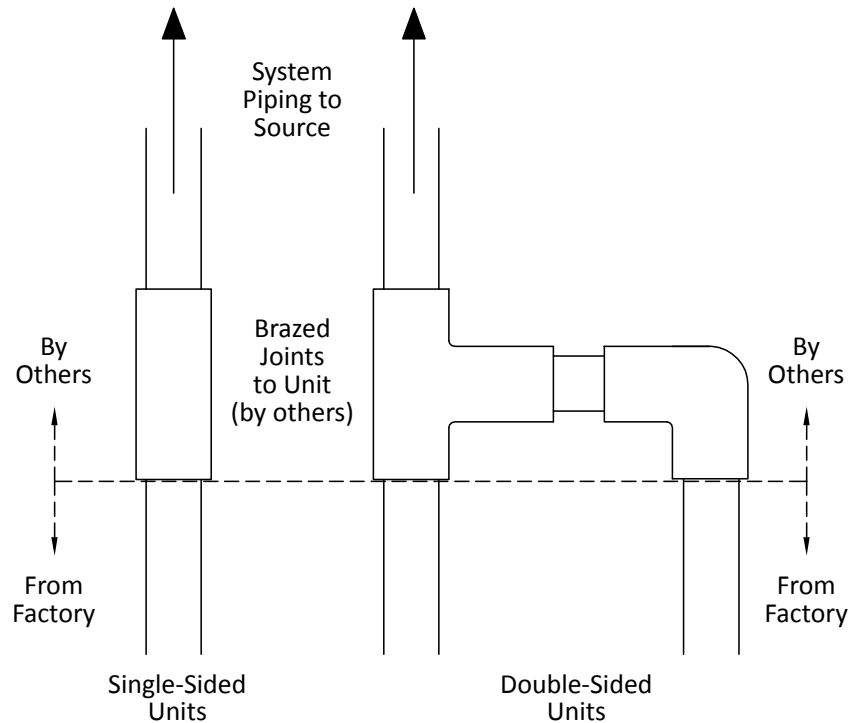

ELECTRICAL CONNECTIONS

1. Ensure all electrical power circuits are locked off prior to hook-up.
2. Review wiring diagram or shop drawing.
3. All factory-installed electrical devices are pre-wired to the electrical service junction boxes at the top of the unit.
4. Electrical service boxes include knockouts for both in-the-wall electrical services and non-inwall electrical services (Figure 5). If in-the-wall services are to be used, connections must be made prior to drywall installation. Non-inwall electrical services should be made after drywall installation.
5. Wiring is factory-installed and routed to the incoming service junction boxes for any preinstalled electrical devices. **NOTE:** On double-sided units, junction boxes are accessible from the “as shown” side of the unit only.
6. **IMPORTANT:** Service connections are to be made in accordance with applicable National Electrical Codes, in addition to state and local codes.

Figure 5.

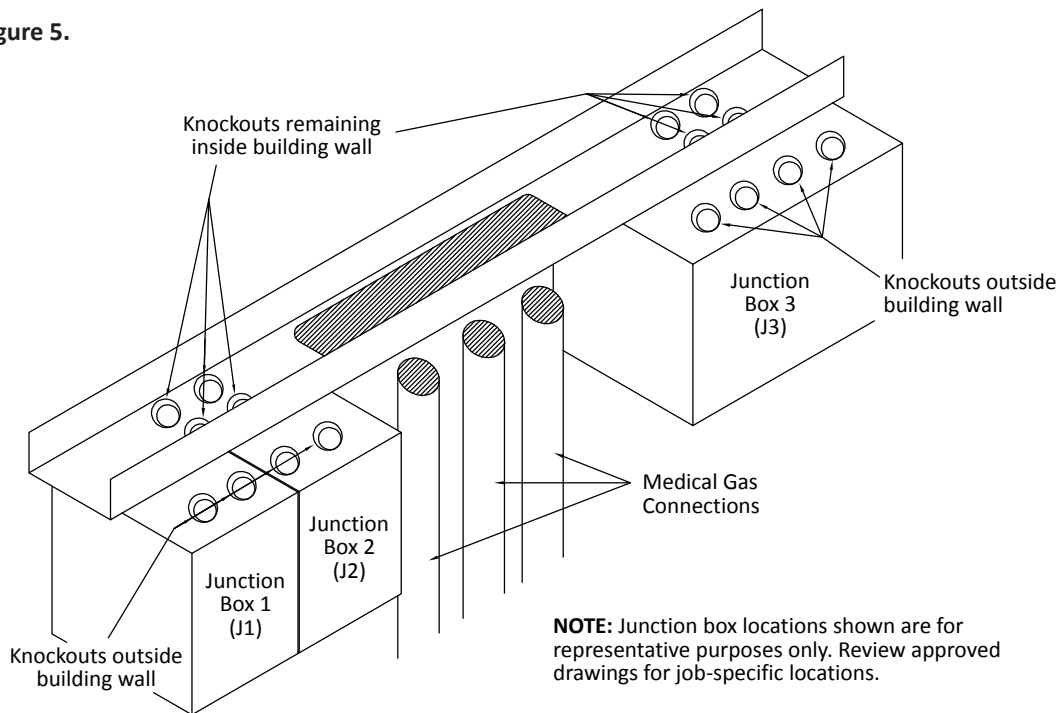

LOW-VOLTAGE CONNECTIONS

1. Empty 3/4" conduits are provided from the low-voltage junction box to the low-voltage compartment, as indicated on the approved drawings.
2. All electrical connections are to be made and tested in accordance with state and local codes.

DRYWALL INSTALLATION

1. Prior to installation of the drywall, ensure that all medical gas piping and any required unexposed electrical connections have been completed.
2. For double-sided Profile units, remove the wood spacers from below the mounting flanges and discard.
3. Pull the component housing out so that the gap behind the vertical side mounting flanges is slightly larger than the drywall thickness (Figure 7). This will allow the drywall material to slide in behind these flanges. The assembly is attached to the vertical studs with four screws in round holes and left slightly loose to allow for this adjustment.
4. For installation around the component housing, cut drywall to size that will allow the material to slip under the lip of the vertical mounting flanges on each side of the housing. A seam will be required in the location of the component housing (Figure 6) At the top and the bottom, cut the drywall in a manner to minimize the gap at the component housing to lessen the amount of caulking required.

NOTE: For installation around the incoming service junction boxes, a rectangular opening should be cut in the drywall so that it just fits over the boxes. Since the junction boxes are above the ceiling line and the boxes protrude out from the building wall, no trim cover will be provided. Any gaps between the junction box and drywall should be filled with either caulking or plaster as required.

5. Attachment of the drywall can be accomplished using standard drywall fasteners directly to the metal studs and drywall supports of the units (use extreme care with screws that are close to either the medical gas piping or the electrical conduits). Perform all taping, joining, texturing and painting before resetting the housing back to its original position (any additional wall coverings may be installed as well).

Figure 6.

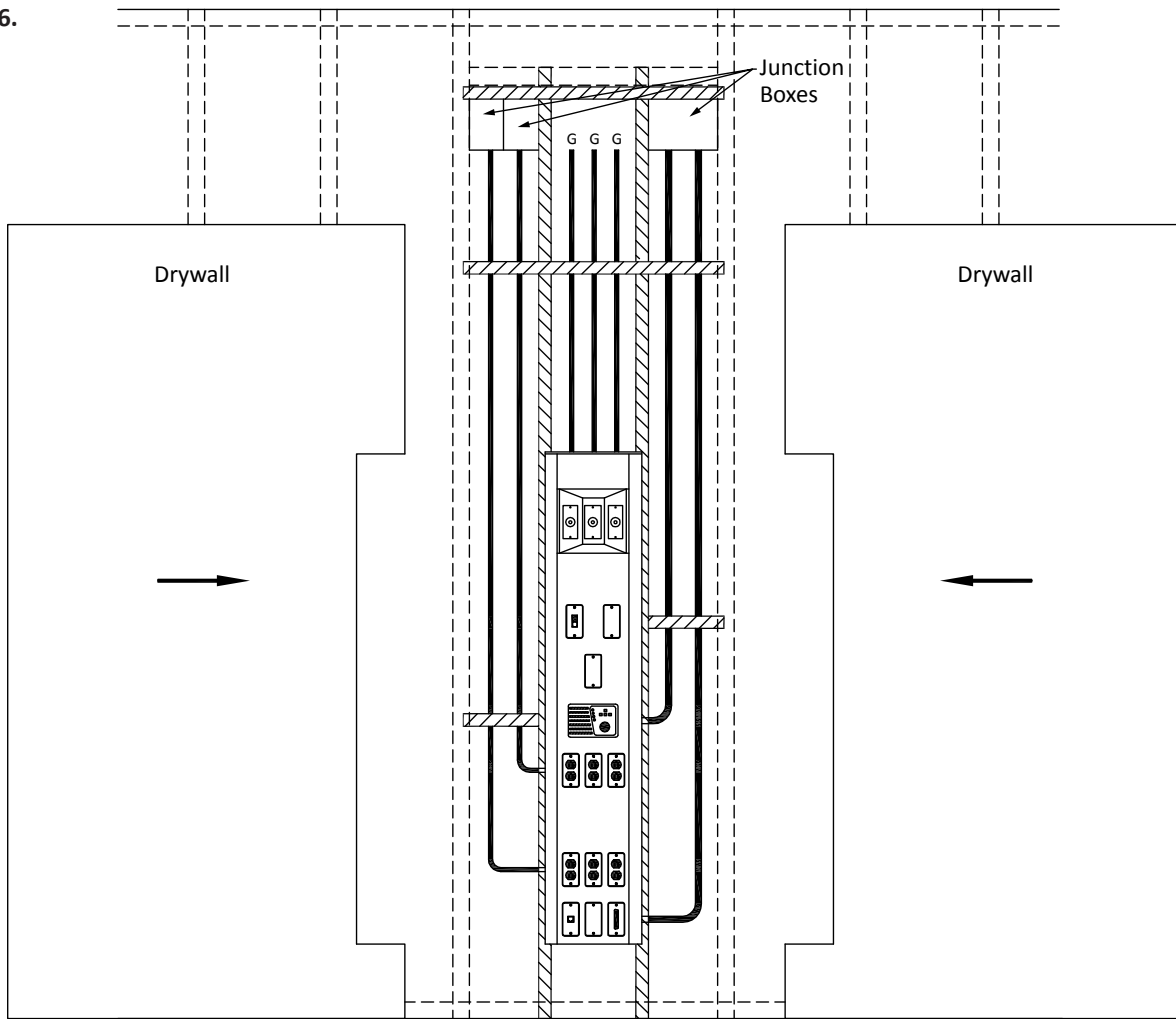

Figure 7.

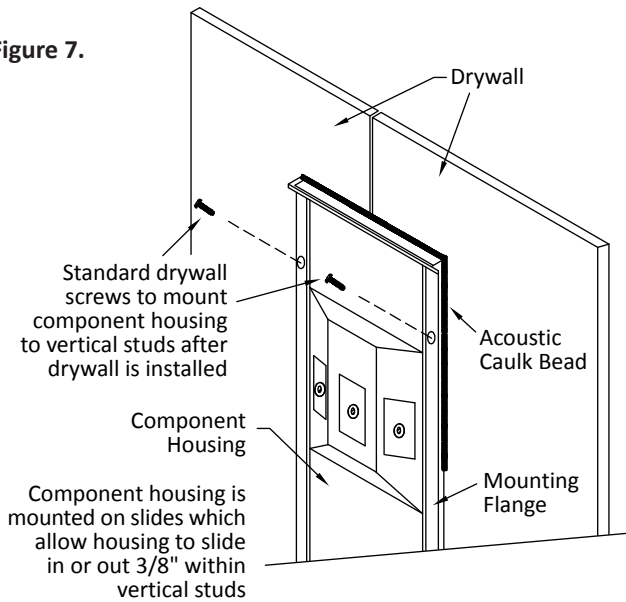
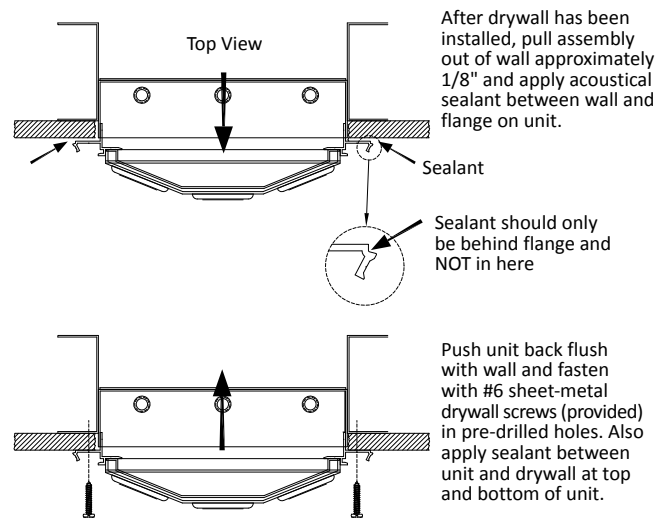

Figure 8.



IMPORTANT: Wainscoting should not be installed under the aluminum flanges of the Profile unit. Ideally, partial wall coverings should be installed after the painted finish trim is attached to the unit. If the coverings are to be installed before finish trim attachment, terminate 0.25" from the outer edge of the non-painted aluminum flange.

6. Once the wall finishes are completed, caulk behind the vertical mounting flanges of the component housing with an acoustical sealant and position it back against the finished wall (Figures 7 and 8). This should be the same position that the medical gas brazing was performed to remove any tension to the brazed connections made.
7. Attach the unit to the metal studs behind the drywall using #8 or #10 sheet metal or drywall screws. Apply acoustical caulk to fill the gap at the top and bottom between the component housing and the drywall to seal off the wall cavity.

FINISH TRIM INSTALLATION

1. Remove the plastic sheet or drop cloth used to cover the component housing during drywall installation.
2. The finish trim top and bottom trim plates are shipped pre-assembled, and are packaged separately. Disassemble the trim (keep all screws, as they will be needed to reassemble the trim).
3. Slide the two vertical finished trim pieces into place from the side and attach them to the vertical mounting flanges with the eight 6-20x3/8" screws provided (Figure 9).
4. Attach the top and bottom trim plates to the vertical mounting flanges using the 6-20x1" screws provided (Figure 9).

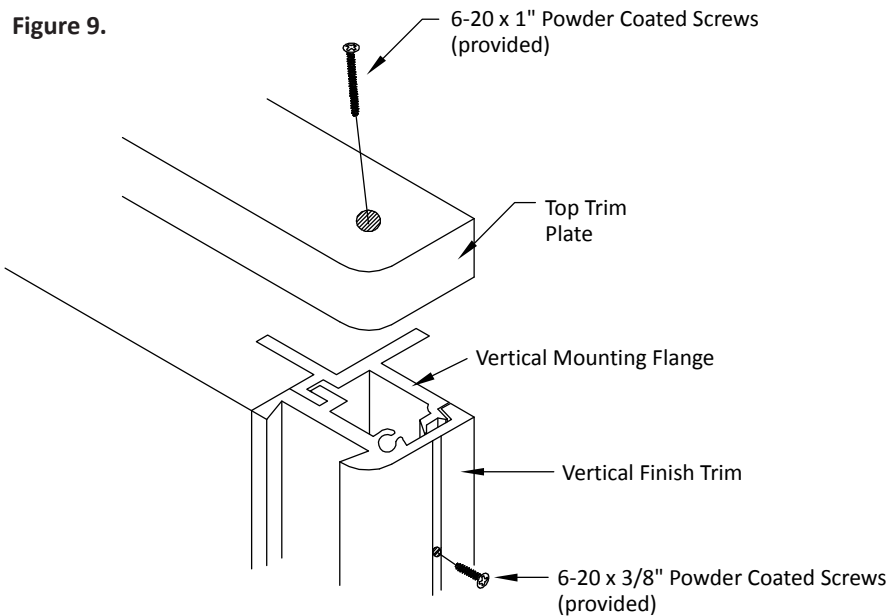

CARE AND MAINTENANCE

1. Clean with mild detergent and warm water. **Do not use lubricants or oils on unit.**
2. Avoid excessive moisture build-up, as it can damage mechanisms in the unit.
3. Disinfect as required with disinfectant approved by the Environmental Protection Agency.
4. To remove difficult spots or stains, use standard household cleansers and a soft-bristled brush.
5. For parts or repairs, contact your sales representative.

INSTALLATION TERMS AND CONDITIONS

Each Modular Services unit, or unit section, shall be completely pre-wired for normal, emergency and low voltage according to the approved submittal. Communication devices and wiring shall be supplied by others. These devices include nurse call, television, code blue, telephone, monitor jacks, etc.

The customer shall be responsible for all electrical conduits (above the junction boxes), wiring hook-up of electrical services, and if applicable, interconnect wiring between sections. All hardware light fixtures shall be installed, wired and lamped by contractor. After installation is complete, the customer shall test equipment functions, as well as electrical receptacles and ground, in accordance with the National Electrical Code.

Medical gas contractor shall be responsible for piping and hook-up of all medical gas services. The medical gas contractor shall be responsible for purging, pressure testing, gas identification, and system certification in accordance with NFPA 99.

Modular Services Company shall have no responsibility or liability for delays, however caused. Owner shall hold Modular Services harmless from damages or injury related to any failure or neglect of owner, its employees, agents or licensees. Modular Services shall not be liable for consequential damages; makes no warranties, expressed or implied; and assumes no obligation other than those expressly contained herein.

WARRANTY

Modular Services Company warrants that all equipment assemblies shall be free from defects in material and workmanship for a period of 12 months from date of the owner's acceptance to the installing contractor or the date the equipment is put into service, whichever comes first. Warranty excludes electric lamps and/or any material not furnished by Modular Services. Warranty does not cover damage due to improper installation and/or abuse.

It is the responsibility of the customer to report any noted product deficiencies to Modular Services immediately upon discovery. It is the responsibility of Modular Services to expediently resolve the discrepancy. Any modification made to the product without the written authorization from Modular Services will void this warranty.

Also, in the event product modifications or repairs are made without the written consent of Modular Services, Modular Services shall not be held liable for any cost associated with the modification or repair.

There are no warranties of fitness which extend beyond the description on the face hereof.



MODULAR
SERVICES COMPANY

500 E. Britton Rd. • Oklahoma City, OK 73114

Tel: 800.687.0938 • Fax: 405.528.0368

www.modularservices.com

info@modularservices.com